



WY Office of Homeland Security Agency Overview Critical Infrastructure Protection



Agency Information



- A division/office within the Governor's office/budget
- Director and Deputy Director appointed by the Governor
- Total of 20 FTE, 2 PTE (including Director & Deputy)
- Biennium budget approximately \$23,403,179
 - General Funds - \$ 1,998,131 (8.5%)
 - Special Revenue - \$ 819,250 (3.5%)
 - Federal Funds - \$20,585,798 (88%)

Agency Mission:

Preparing Wyoming to respond to and recover from all-hazards

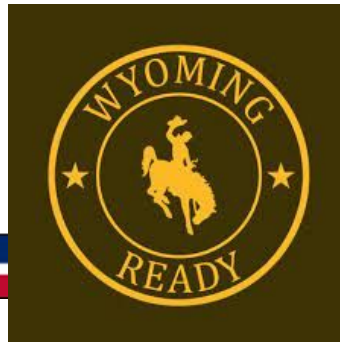

Statutes

- **Wyoming Homeland Security Act**
 - Title 19 - Defense Forces and Affairs
 - Chapter 13 - Wyoming Office of Homeland Security
- **19-13-108**
 - Local programs; authorized; local homeland security plan; coordinators; appointment and removal.
 - Each political subdivision of this state shall establish a local homeland security program in accordance with the state homeland security plan and program.
 - County and municipal Homeland Security Coordinators (Emergency Managers) work for the jurisdiction and are appointed by the Governor.



Definition 19-13-102(a)(ii)

"Homeland security" means the **preparation for** and the **carrying out** of all **emergency functions** essential to the **recovery and restoration** of the economy by supply and resupply of resources to **meet urgent survival and military needs**, other than functions for which military forces are primarily responsible, necessary to **deal with disasters** caused by enemy attack, sabotage, terrorism, civil disorder or other hostile action, or by fire, flood, earthquake, other natural causes and other technological, industrial, civil and political events. These **functions include without limitation** the **coordination of fire-fighting** services, **police** services, **medical and health** services, **rescue, engineering**, attack warning services, communications, **radiological** events, **evacuation** of persons from stricken areas, **emergency welfare services** (civilian war aid), **emergency transportation**, existing or **properly assigned functions** of plant **protection, temporary restoration** of public utility services, **mitigation** activities in areas threatened by natural or technological hazards, and **other functions related to civilian protection**, together with all other activities necessary or incidental to the preparation for any carrying out of the foregoing functions;



Mission Areas

- ❖ **Prevention/Protection (Preparedness) (Blue Sky)**
 - Training & Exercise
 - Preparedness Grant Funding (FEMA & DHS)
 - Information Sharing
- ❖ **Response (Grey Sky)**
 - Coordination of state and federal resources in support of local jurisdictions
- ❖ **Recovery (Grey Sky)**
 - FEMA Disaster funding (Stafford Act)
 - Assistance with re-establishment of essential services
- ❖ **Mitigation (Blue Sky)**
 - FEMA grants to help build community resilience by reducing the consequences of future events



Emergency Management Cycle

- **Preparedness**
 - “Left of Boom” activities
- **Response**
 - “Boom” - the bad thing happened
- **Recovery**
 - “Now what?”
 - “What’s next?”
- **Mitigation**
 - Avoid “boom” or at least reduce the cascading consequences
 - For every \$1 invested here, some \$6 is saved in response (long term)



Common Threats & Hazards

- Floods
- Wildland Fires
- Tornadoes/Severe Weather
- Blizzards/Winter Storm
- Hazardous Materials
- Cyber Attack
- Others locally



“The ability to protect the critical infrastructure and key resources (CIKR) of the United States is vital to our national security, public health and safety, economic vitality, and way of life.”

National Infrastructure Protection Plan

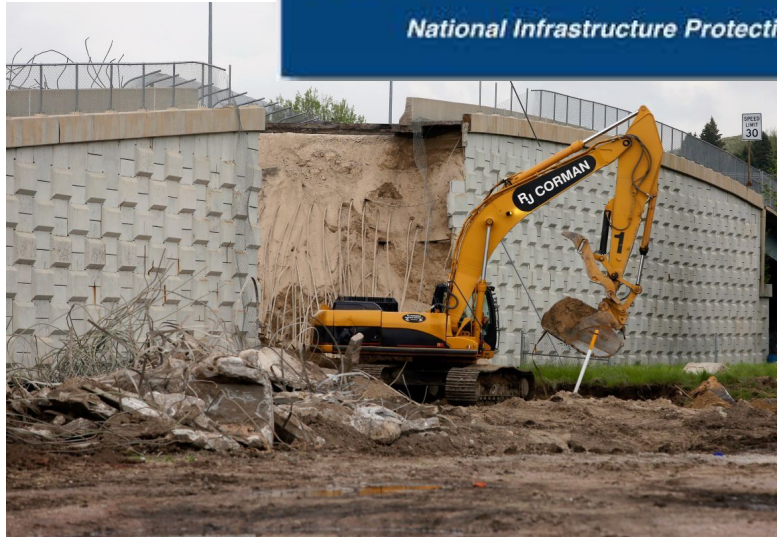

Command vs Coordination

- **Incident Command Post (ICP)**
 - Command
 - Crisis Management (the “what”)
 - Scalable
- **Emergency Operations Center (EOC)**
 - Coordination
 - Consequence Management (the “so what” like evacuations or shelters)
 - Activated upon IC, EM or elected official request
 - Staffing made up of local agency people who can make decisions/commit resources (in theory)
- **WOHS - State Response Coordination Center (SRCC)**
 - Coordinate state and federal resources in support of local jurisdictions and other state agencies
 - **Critical Infrastructure position serves as a key liaison to public/pvt partners during a “gray sky” activation to support the response**



Key State Agency Partners

- Any key stakeholders applicable to the specific situation



Community Lifelines

PRIORITY: Life Saving

EFFORT: Stabilization of Lifelines



Safety and Security



Food, Water, Sheltering



Health and Medical



Energy (Power & Fuel)



Communications



Transportation



Hazardous Material

A lifeline enables the continuous operation of **government functions** and **critical business** and is essential to **human health** and **safety** or **economic security**.



Green

No disruption to services by the incident, or restoration to baseline has been achieved



Grey

No clear understanding/unknown extent of impacts to the lifeline



Yellow

A solution has been identified, but is in process implementation



Red

The incident has caused an impact, no clear way forward right now



Critical Infrastructure/Key Resources (CIKR)

"Critical infrastructure" means any asset, system or network located in Wyoming, whether physical or virtual, that is vital to the state's security, economic security, public health or safety. "Critical infrastructure" includes but is not limited to water infrastructure, transportation infrastructure, electrical energy generation facilities, fuel import facilities, refineries and telecommunications facilities;

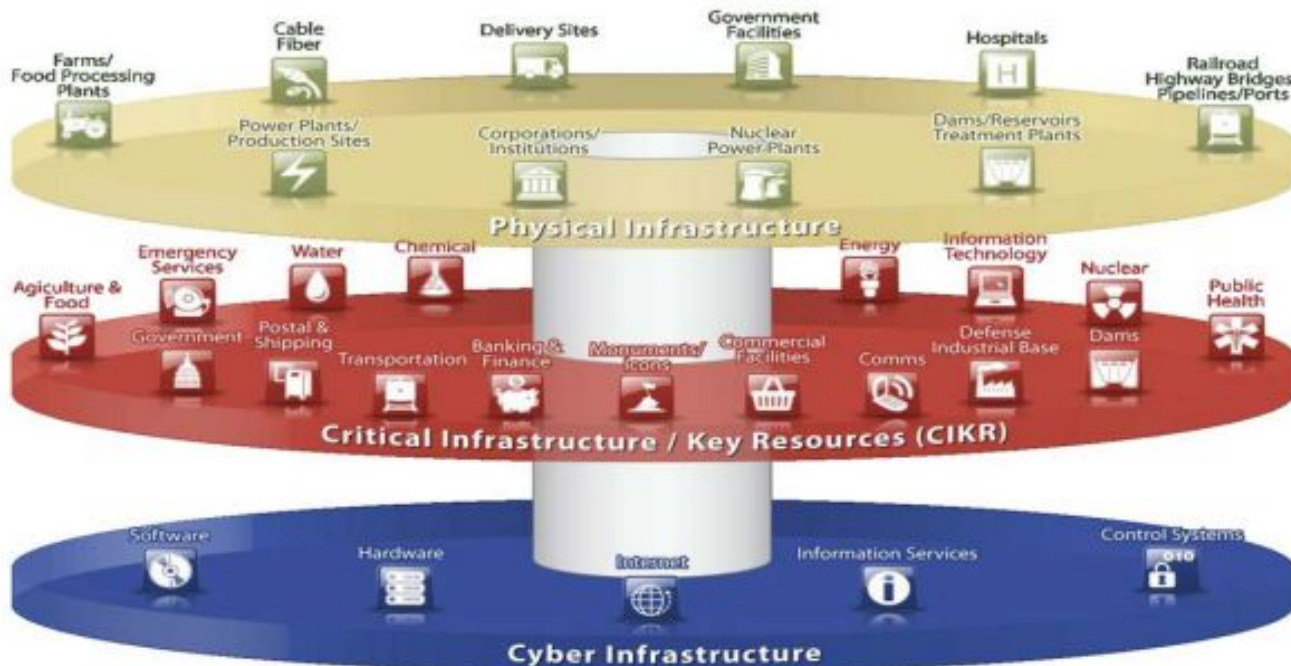

Critical Infrastructure

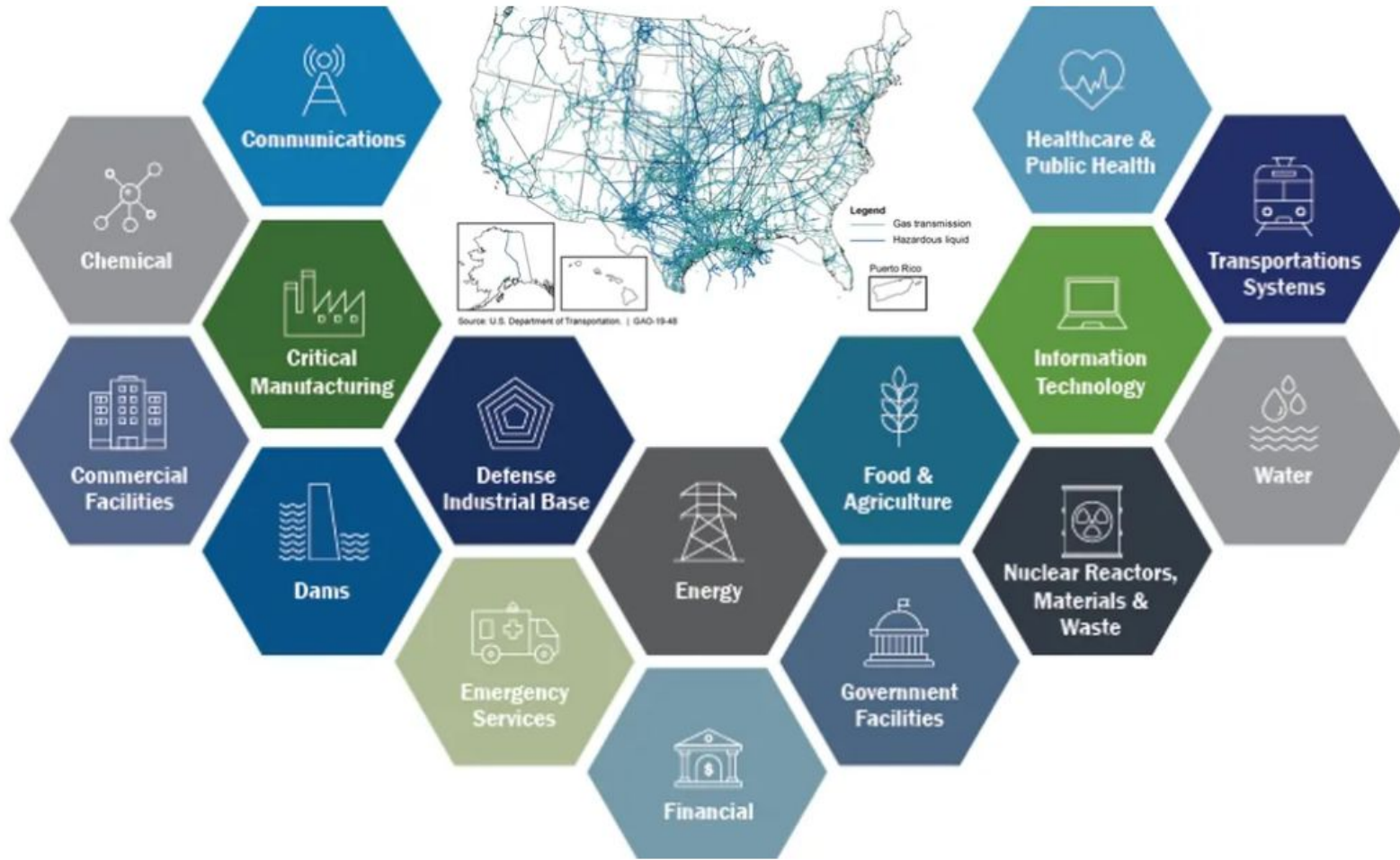

CRITICAL INFRASTRUCTURE AND KEY RESOURCES AS SYSTEMS



Key Activities for the protection of Critical Infrastructure/Key Resources

- **Identify and verify** threats including suspicious cyber activity
- **Understand** infrastructure systems, partners, incidents and vulnerabilities
- **Build and maintain** partnerships (both public and private)
- **Share** timely and actionable information/intelligence across public/private networks
- **Collaborate** with partners, both public and private, to mitigate risk

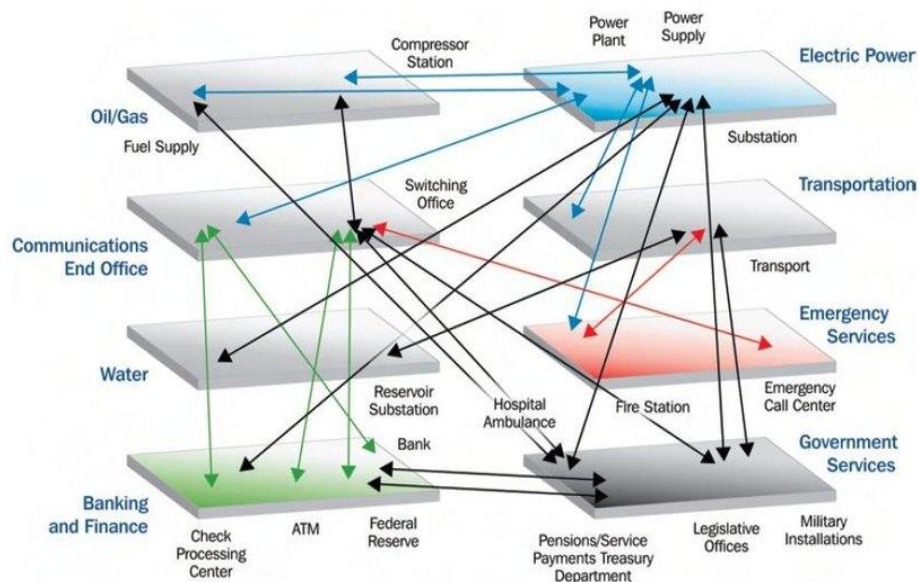

U.S. Pipeline Systems' Basic Components and Vulnerabilities

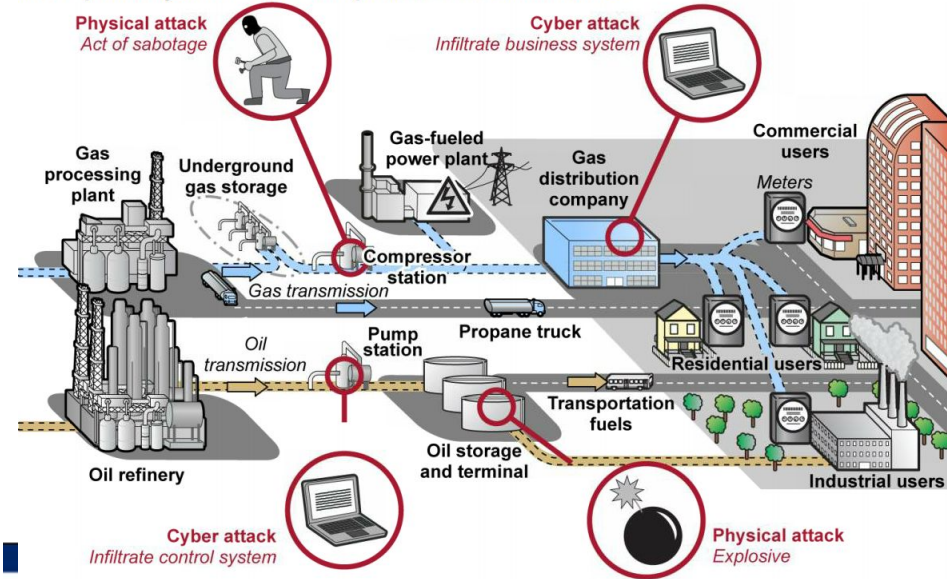

Source: GAO analysis of Transportation Security Administration information. | GAO-19-48

Key Activities for the Critical Infrastructure Protection position

- Liaise with DHS and other federal partners
- Support public/private entities around Wyoming to “harden the target” and prepare for incidents
- Provide CIKR information and resources to state, tribal, county, city, and other entities
- Integrate other WOHS and “whole of state” resources into CIKR protection (e.g. grants, training, exercise, etc) by convening experts

Risk Management Framework

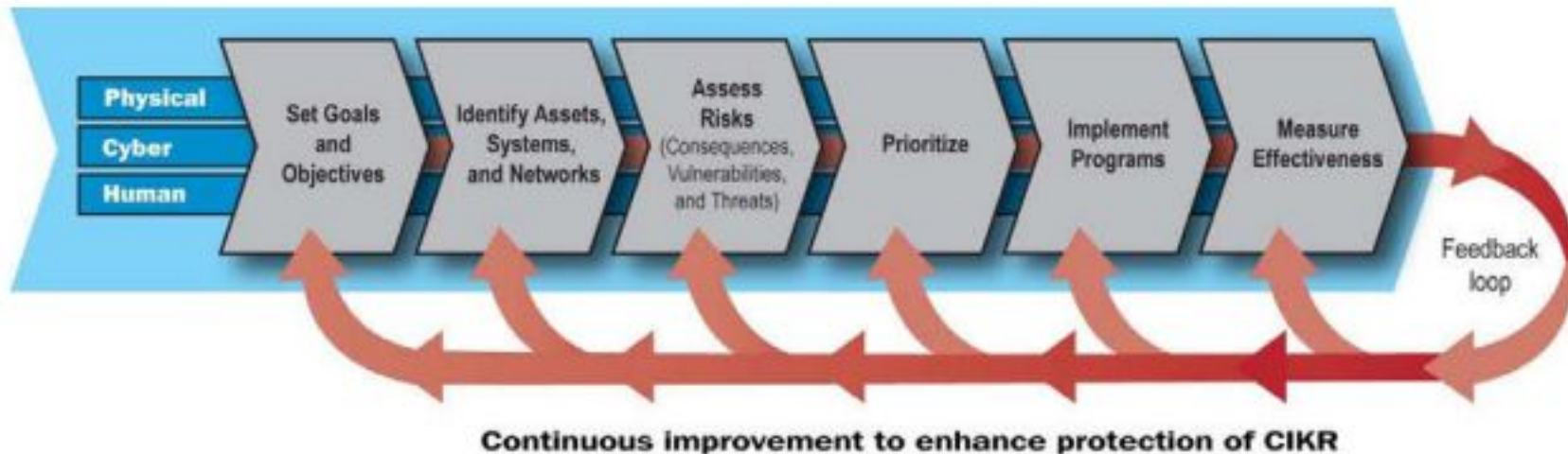

Fusion Center

- Connects the dots between seemingly unrelated bits of information across jurisdictional lines

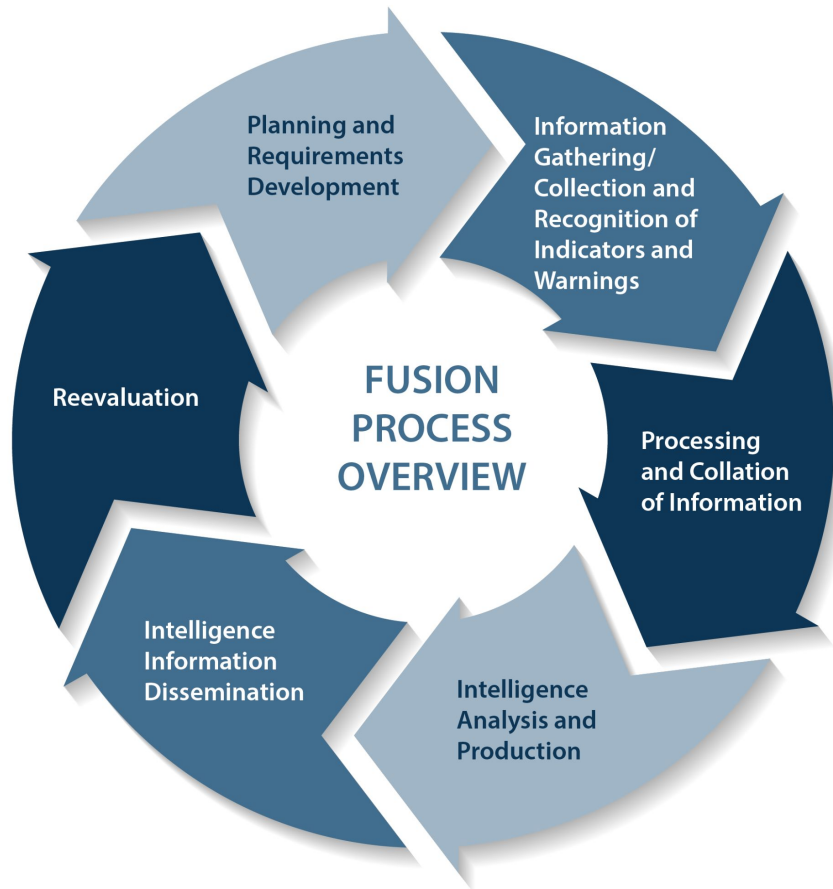

Threat evaluation and information sharing- WIAT

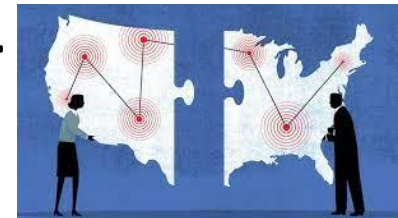

The Wyoming Information and Analysis Team (WIAT)

- Coordination of multiple local, state and federal partners
 - WOHS Cyber and Critical Infrastructure position is a member of the team who brings CI expertise and focus to the broader team of threat/intelligence experts
- Information is combined from various sources and analyzed to create intelligence
- Integrated with other state Fusion Centers for shared threat awareness
- Decisions made on who the intelligence should be shared with
- Delivers Threat Liaison Officer (TLO) class to better empower locals to “see something, say something” in their communities

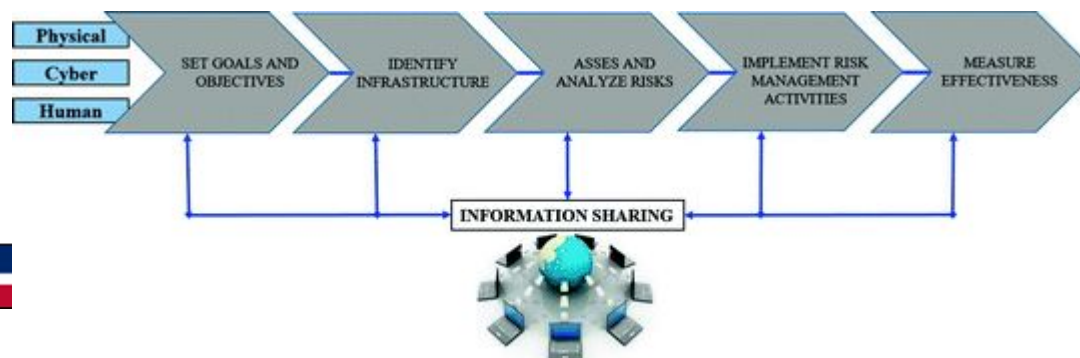

Cyber Assistance Response Effort (CARE Team)

Formally established through EO 2023-02

State agencies

- WY Office of Homeland Security - WOHS (lead)
- Enterprise Technology Services - ETS
- Computer Crimes Team - DCI
- WY Information Analysis Team - WIAT
- WY National Guard

Federal agencies

- Federal Bureau of Investigation - FBI
- Dept of Homeland Security, Intelligence and Analysis - DHS
- Cybersecurity and Infrastructure Security Agency - CISA



Cyber Security

- Cyber Assistance Response Effort (CARE)
 - State and Federal partners coordinating response and recovery efforts
- “Normalize” the Event

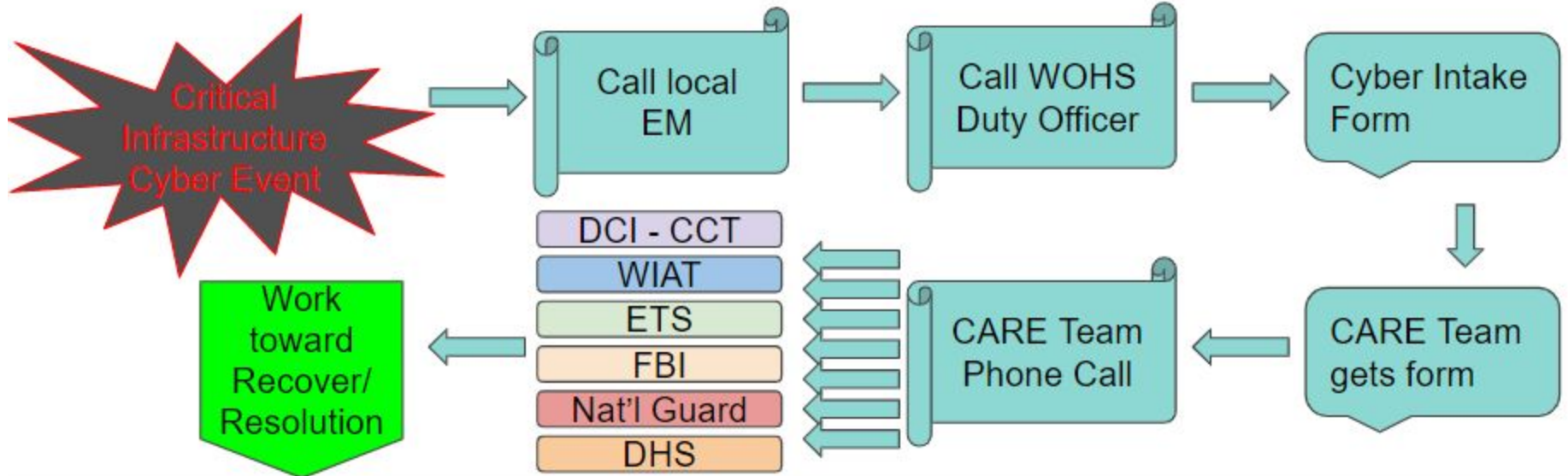

Cyber Security on the State Network

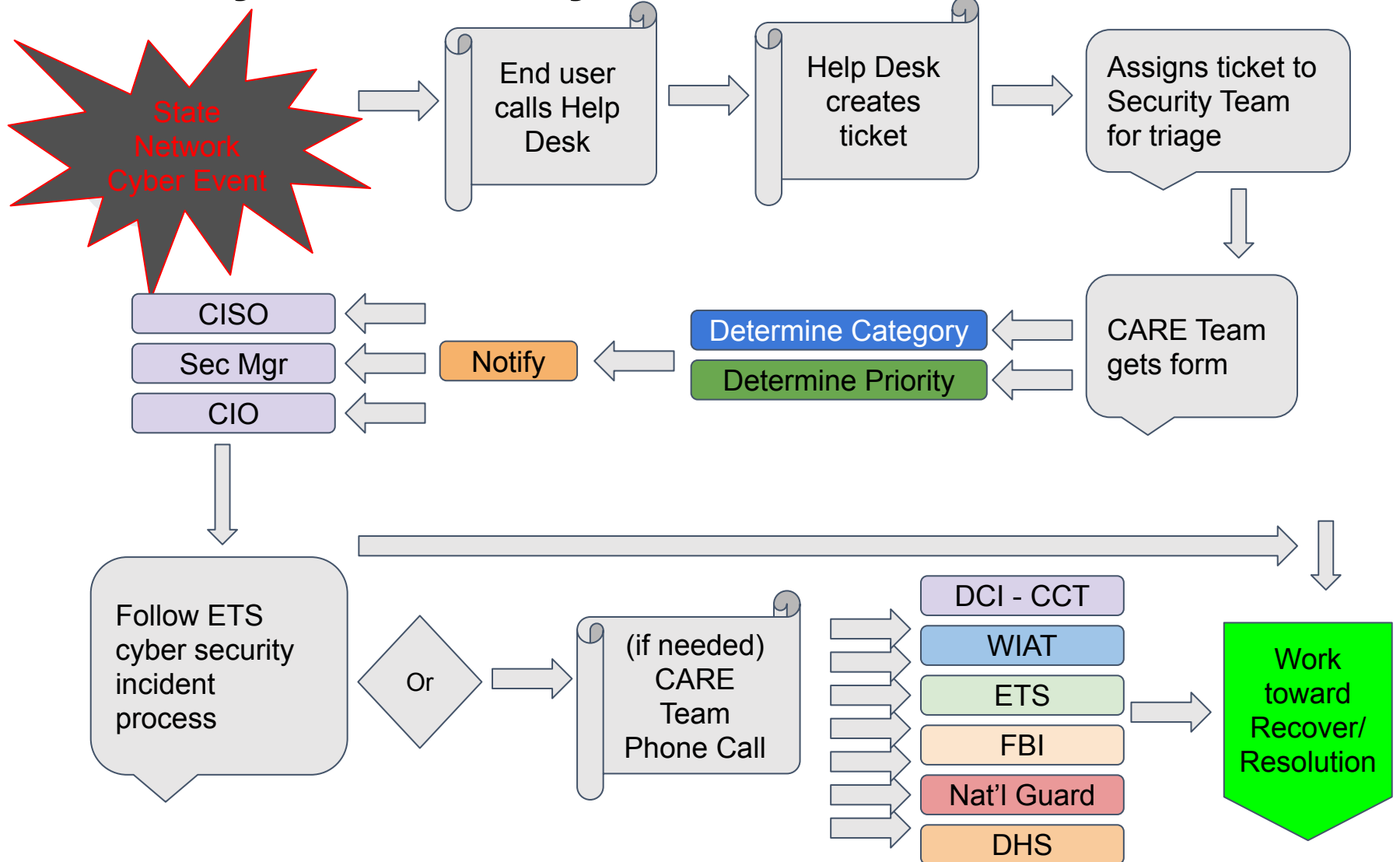

Summary

- WOHS coordinates the “whole of state” response to threats and hazards
- WOHS leads the “left of boom” readiness
- Critical Infrastructure & Cyber position
 - Focal point for CIKR resources
 - Integral to WIAT operations
 - Coordinator for CARE efforts
 - Force multiplier of pub/pvt partnerships before, during, and after crisis situations

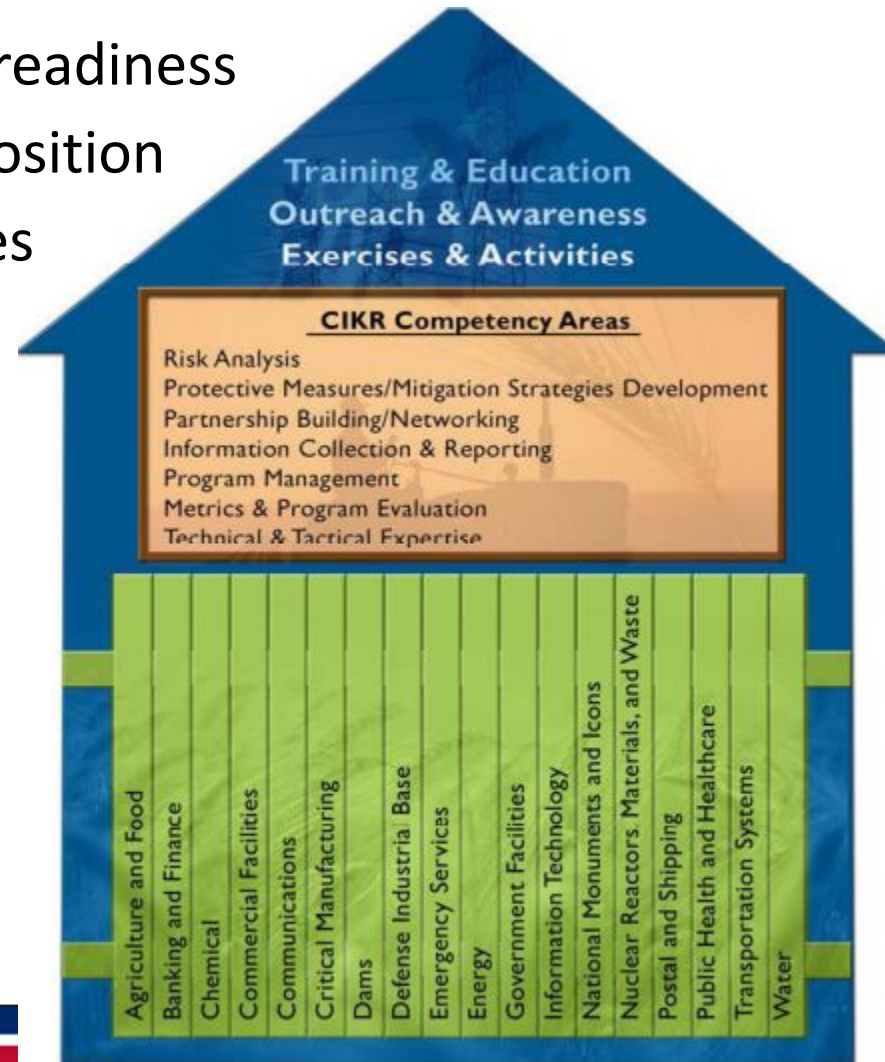

Questions & Contact Information

Any questions?



Contact Information for the Wyoming Office of Homeland Security

5500 Bishop Blvd

Cheyenne, WY 82009

307-777-4900

307-630-2767 (24/7 Duty Officer)

dutyofficer@wyo.gov

hls.wyo.gov

Wyoming Info Sharing Platform (WISP) - wohs.us

